



**PUBLIC NOTICE**

**Public Works Committee**

**Thursday, June 18, 2026 at 4:00 PM**

**City Hall Small Conference Room, 410 E Leffler St,**

**Dodgeville, WI**

---

**AGENDA**

**I. CALL TO ORDER AND ROLL CALL**

**II. APPROVAL OF MINUTES**

- [1.](#) Approval of minutes from May 21, 2026
- [2.](#) Approval of minutes from June 10, 2026

**III. NEW BUSINESS**

- [3.](#) Discussion and possible action on Design Agreement with Vierbicher relating to City Hall Site Work Project
- [4.](#) Discussion on a Certified Survey Map relating to City Hall lot lines
- [5.](#) Discussion and possible action to approve resolution for Downtown Iowa St snow removal policy
- [6.](#) Discussion and possible action on a utility bill adjustment request for 109 E Madison St
- [7.](#) Discussion and possible action on purchasing new garbage cans for the downtown area

**IV. OLD BUSINESS**

**V. ADJOURN**

8. Motion to Adjourn

*Any person who has a qualifying disability, as defined by the Americans with Disabilities Act, that requires the meeting or material at the meeting to be in an accessible location or format, must contact the City Clerk at the address listed above or call 930-5228, prior to the meeting so that any necessary arrangements can be made to accommodate each request.*



**MINUTES**

**Public Works Committee Meeting**

**Thursday, May 21, 2026 at 4:00PM**

**City Hall, 410 E Leffler Street, Dodgeville, WI**

**I. CALL TO ORDER AND ROLL CALL**

The meeting was called to order at 4:00pm by Chair Jeff “Potsie” Weber. Members present: Tom DeVoss, Mike Olson, Jeff “Potsie” Weber. Others present: Evan Chambers (Town & Country Engineering), Logan Hanson (Vierbicher), Eric Hagen (City Attorney), Dylan Wadzinski (Director of Public Works)

**II. APPROVAL OF MINUTES**

- 1. Approval of minutes from April 30, 2026
- 2. Approval of minutes from May 12, 2026

Motion by DeVoss, second by Olson to approve minutes from April 30, 2026 and May 12, 2026. Voice vote 3-0. Motion carried.

**III. NEW BUSINESS**

- 3. Discussion and possible action to approve airlift proposal from Municipal Well and Pump relating to the well #8 rehabilitation project  
Motion by Olson, second by DeVoss to approve airlift proposal from Municipal Well and Pump in the amount of \$26,710.00. Voice vote 3-0. Motion carried
- 4. Discussion and possible action to approve Well #8 rehabilitation proposal from Municipal Well and Pump  
Motion by Olson, second by DeVoss to approve proposal from Municipal Well and Pump not to exceed \$27,540.00. Voice vote 3-0. Motion carried
- 5. Discussion on Streets Capital Improvement Plan Analysis  
Discussion only topic. No action taken
- 6. Discussion and possible action on purchasing new garbage cans for the downtown area  
Discussion only topic. No action taken
- 7. Discussion and possible action on a utility bill adjustment request for 109 E Madison St  
Discussion only topic. No action taken

**IV. OLD BUSINESS**

**V. ADJOURN**

- 8. Motion to adjourn

Motion by DeVoss, second by Olson to adjourn. Voice vote 3-0. Motion carried

Time: 5:08pm



**PUBLIC NOTICE**

**Public Works Committee**

**Wednesday, June 10, 2026 at 4:00 PM**

**City Hall Small Conference Room, 410 E Leffler St,**

**Dodgeville, WI**

**AGENDA**

Call to order 4:00 PM  
Members present: Mike, Tom, Michelle  
Also present: Dylan (DPW), Logan (Vierbicher)

**I. CALL TO ORDER AND ROLL CALL**

**II. NEW BUSINESS**

- 1. Discussion and possible action on future street reconstruction projects Motion by Tom to wait until 2027 to do S Douglas with W Division St and to also consider Center St. 2nd by Michelle. Pass 3-0
- 2. Discussion and possible action to approve contract with Vierbicher relating to the TID #3 Truck Stop Development Project Motion by Tom to approve. 2nd by Michelle. Pass 2-0, 1 abstained
- 3. Discussion and possible action to approve contract with Vierbicher relating to the design and engineering for the Bea Ann Drive stormwater repairs Motion by Mike to approve. 2nd by Michelle. Pass 3-0
- 4. Discussion and possible action to approve resolution for new stop sign at the intersection of E Grace St and E Madison St Motion by Michelle to approve. 2nd by Mike. Pass 3-0
- 5. Discussion and possible action to approve amendment to Section 7.07(c) Parking Prohibited at All Times and Section 7.07(p) Handicap Parking Spaces relating to creating no parking along S Douglas St and W North St and designating a handicap stall for the Police Department

**III. OLD BUSINESS**

Motion by Mike to approve. 2nd by Michelle. Pass 3-0

**IV. ADJOURN**

- 6. Motion to Adjourn Motion by Michelle to adjourn. 2nd by Mike. Pass 3-0  
Meeting adjourned at 4:44 PM

*Any person who has a qualifying disability, as defined by the Americans with Disabilities Act, that requires the meeting or material at the meeting to be in an accessible location or format, must contact the City Clerk at the address listed above or call 930-5228, prior to the meeting so that any necessary arrangements can be made to accommodate each request.*

# CITY OF DODGEVILLE - NEW CITY HALL

## SITE IMPROVEMENTS CITY OF DODGEVILLE, WI

**vierbicher**  
planners | engineers | advisors

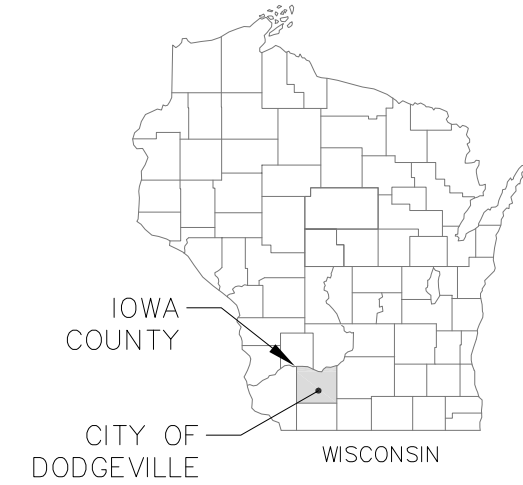

PROJECT LOCATION

SHEET NO.	DESCRIPTION
1	TITLE SHEET
2	GENERAL NOTES
3	EXISTING CONDITIONS
4	OVERALL SITE PLAN
5	SITE PLAN
6	GRADING PLAN
7	UTILITY PLAN
8	DETAILS

### SITE BENCHMARKS

- XXXXX  
XXXXX  
XXXXX  
XXXXX  
ELEV = XXXXX
- XXXXX  
XXXXX  
XXXXX  
XXXXX  
ELEV = XXXXX
- XXXXX  
XXXXX  
XXXXX  
XXXXX  
ELEV = XXXXX



THE LOCATION OF EXISTING UTILITIES, BOTH UNDERGROUND AND OVERHEAD ARE APPROXIMATE ONLY AND HAVE NOT BEEN INDEPENDENTLY VERIFIED BY THE OWNER OR ITS REPRESENTATIVE. THE CONTRACTOR SHALL BE RESPONSIBLE FOR DETERMINING THE EXACT LOCATION OF ALL EXISTING UTILITIES WHETHER SHOWN ON THESE PLANS OR NOT, BEFORE COMMENCING WORK, AND SHALL BE FULLY RESPONSIBLE FOR ANY AND ALL DAMAGES WHICH MIGHT BE CAUSED BY THE CONTRACTOR'S FAILURE TO EXACTLY LOCATE AND PRESERVE ANY AND ALL UTILITIES.

CALL DIGGER'S HOTLINE  
1-800-242-8511

TITLE SHEET

CITY OF DODGEVILLE - NEW CITY HALL  
CITY OF DODGEVILLE  
IOWA COUNTY, WISCONSIN

REVISIONS		REVISIONS	
NO.	DATE	NO.	DATE

DATE	AUGUST 2025
DRAFTER	JCRA
CHECKED	LHAN
PROJECT NO.	250308
SHEET	5
1 OF	5

ISSUED DATE: 08/15/2025





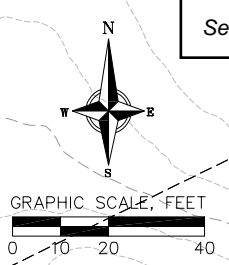
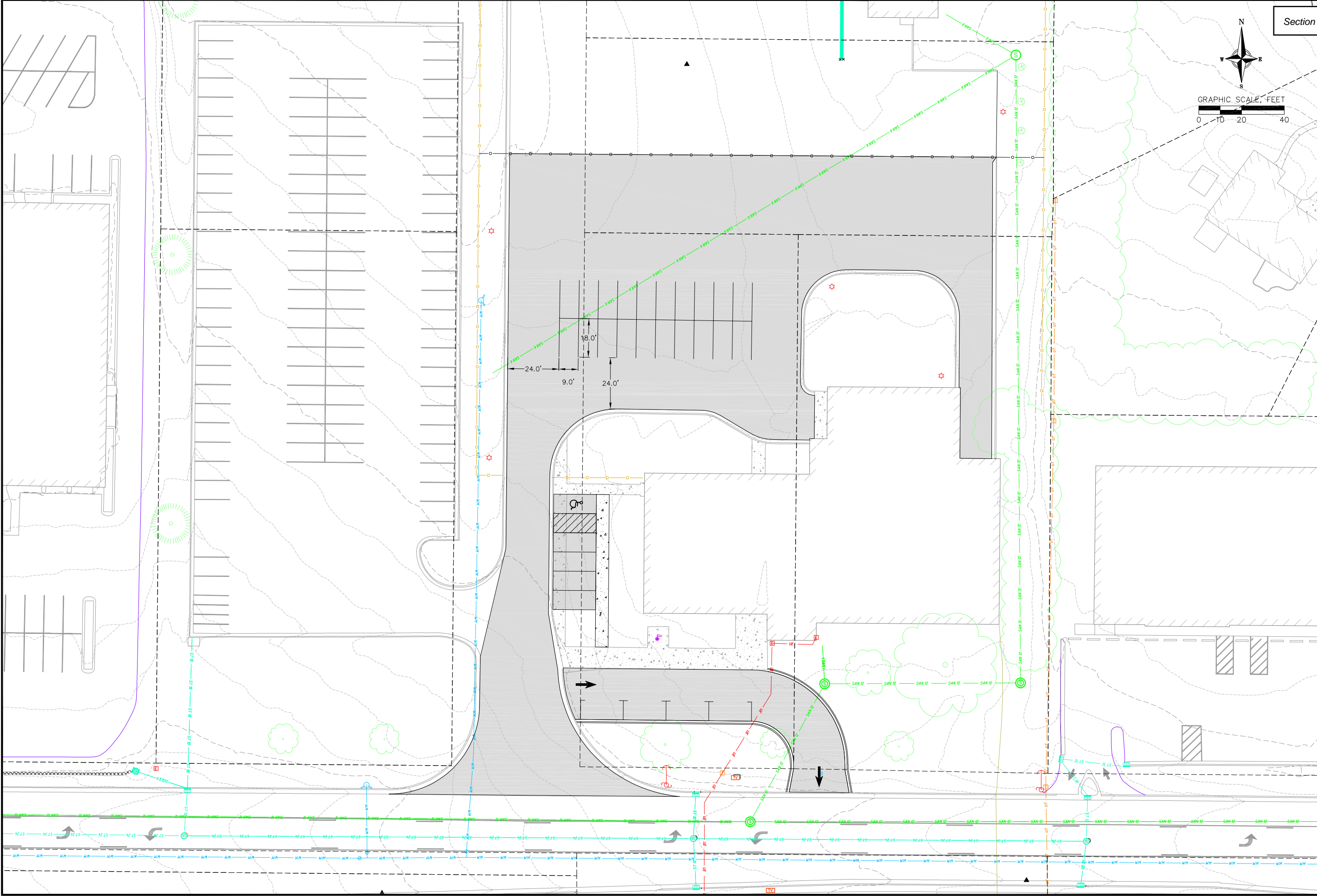

Section III, Item #3.

**vierbicher**  
 planners | engineers | advisors

**OVERALL SITE PLAN**  
 CITY OF DODGEVILLE - NEW CITY HALL  
 CITY OF DODGEVILLE  
 IOWA COUNTY, WISCONSIN

REVISIONS		REVISIONS	
NO.	DATE	NO.	DATE

DATE: AUGUST 2025  
 DRAFTER: JCRA  
 CHECKED: LHAN  
 PROJECT NO.: 250308  
 SHEET: 4 OF 8





15 Aug 2025 - 9:15a R:\Dodgeville, City of\250308 - New City Hall\CADD\Dodgeville - City Hall - Utility Plan.dwg By: jara

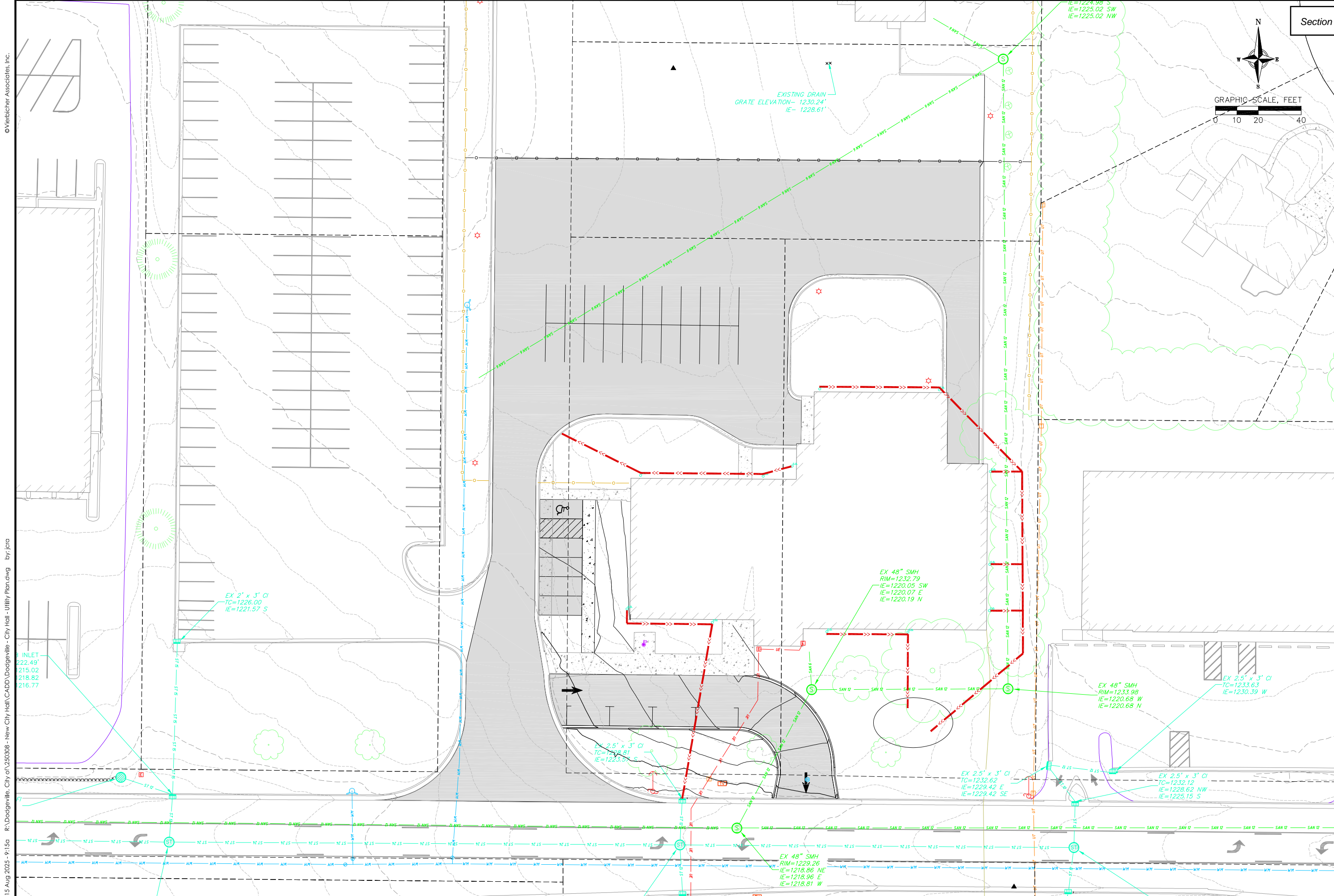

Section III, Item #3.

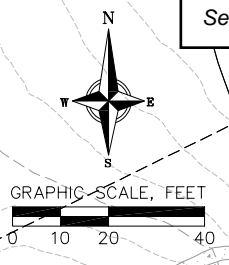

**vierbicher**  
 planners | engineers | advisors

**UTILITY PLAN**  
 CITY OF DODGEVILLE - NEW CITY HALL  
 CITY OF DODGEVILLE  
 IOWA COUNTY, WISCONSIN

NO.	DATE	REVISIONS	REMARKS

DATE: AUGUST 2025  
 DRAFTER: JCRA  
 CHECKED: LHAN  
 PROJECT NO.: 250308  
 SHEET: 11

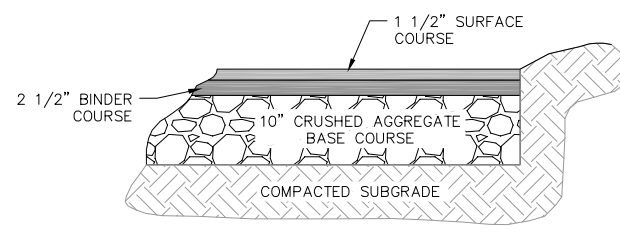

BITUMINOUS PAVEMENT DRIVES

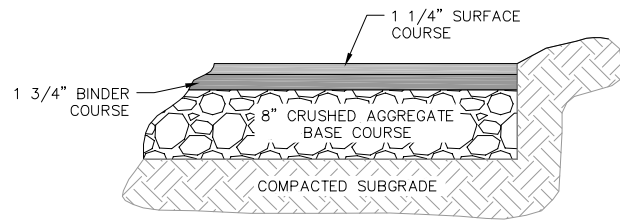

BITUMINOUS PAVEMENT PARKING LOT

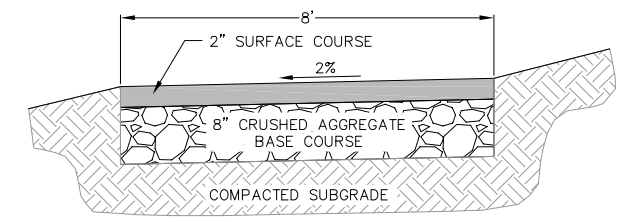

BITUMINOUS PAVEMENT BIKE PATH



1 SITE PAVEMENT  
1 NOT TO SCALE

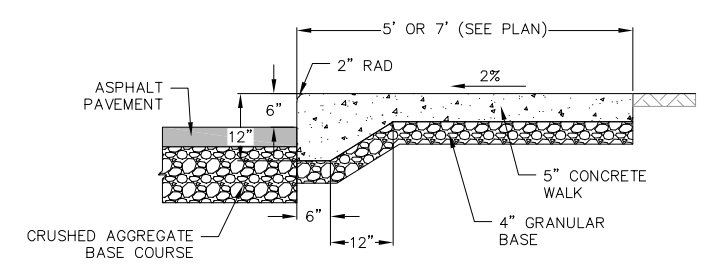

1 CURBED SIDEWALK SITE DETAIL  
1 NOT TO SCALE

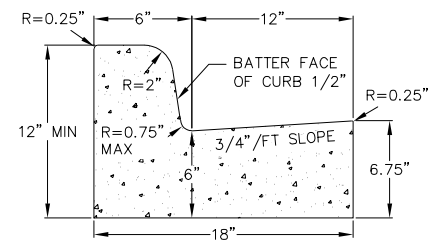

1 CURB AND GUTTER CROSS SECTION

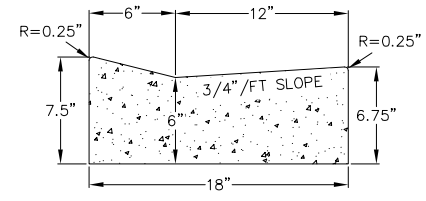

1 DRIVEWAY GUTTER CROSS SECTION

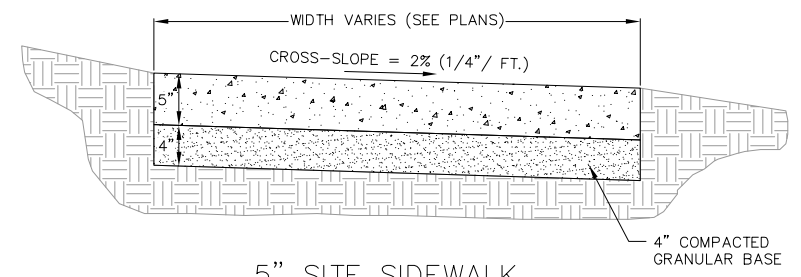

1 5" SITE SIDEWALK

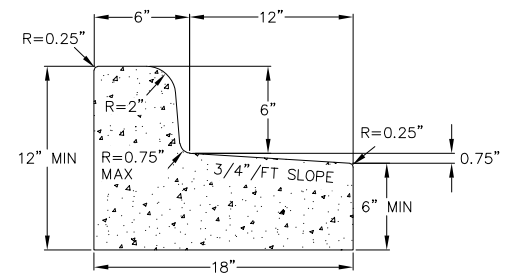

1 CURB AND GUTTER REJECT SECTION

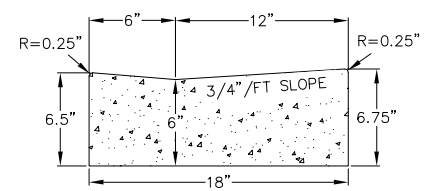

1 HANDICAP RAMP GUTTER CROSS SECTION

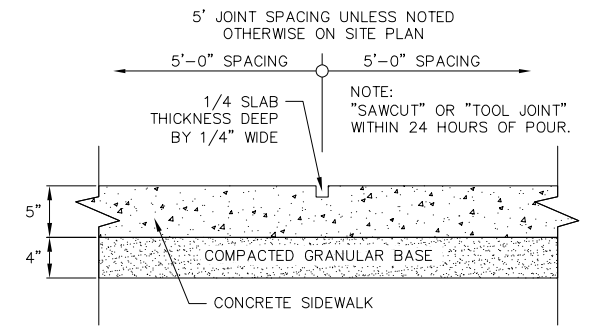

1 SIDEWALK CONTROL JOINT

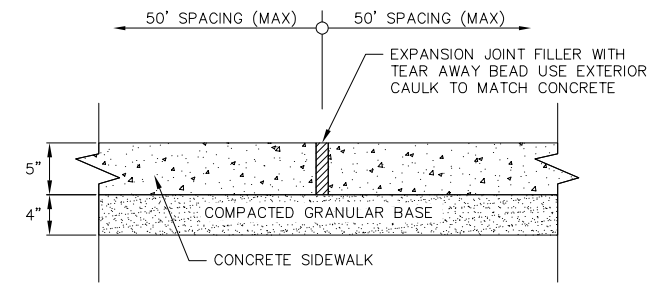

1 SIDEWALK EXPANSION JOINT



1 18" CONCRETE CURB AND GUTTER  
1 NOT TO SCALE

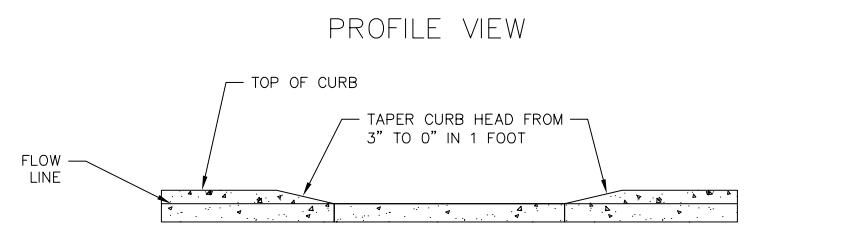

1 CURB CUT PROFILE VIEW

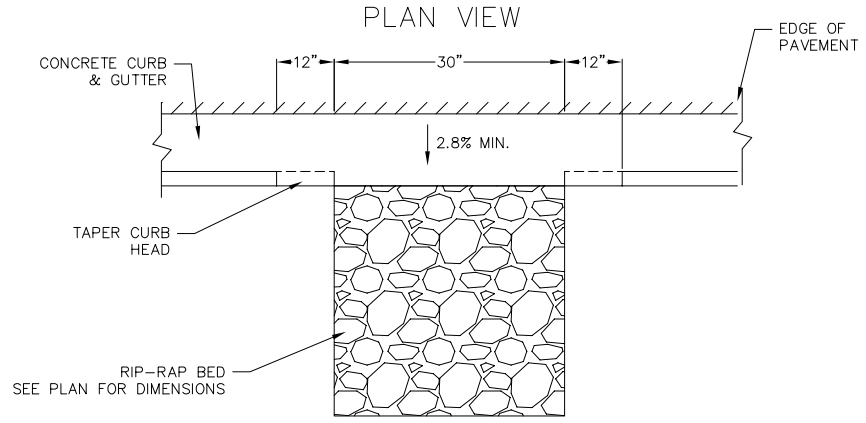

1 CURB CUT PLAN VIEW



1 CURB CUT  
1 NOT TO SCALE

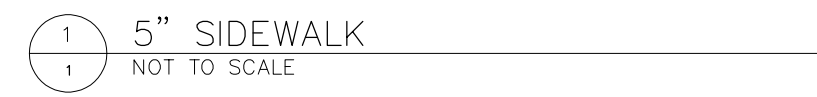

1 5" SIDEWALK  
1 NOT TO SCALE

DETAILS

CITY OF DODGEVILLE - NEW CITY HALL  
CITY OF DODGEVILLE  
IOWA COUNTY, WISCONSIN

REVISIONS	NO.	DATE	REMARKS

DATE: AUGUST 2025  
DRAFTER: JCRA  
CHECKED: LHAN  
PROJECT NO.: 25030  
SHEET: 12



**CITY OF DODGEVILLE  
RESOLUTION NO. 2026-\_\_\_\_\_**

**CITY OF DODGEVILLE DOWNTOWN IOWA ST SNOW REMOVAL POLICY**

WHEREAS, the Common Council of the City of Dodgeville finds it necessary to establish a clear and uniform policy governing snow removal operations within the downtown Iowa Street corridor; and

WHEREAS, “snow removal operations” means the physical relocation of snow from one area to another, including the removal of snow accumulations from street parking stalls, and does not include routine snowplowing or salting activities; and

WHEREAS, the Common Council seeks to promote public safety, ensure efficient snow removal operations, and clearly define the responsibilities of the City and adjacent property owners; and

WHEREAS, Iowa Street between Spring Street and Walnut Street is a primary downtown corridor requiring coordinated snow removal operation efforts;

NOW, THEREFORE, BE IT RESOLVED BY THE COMMON COUNCIL OF THE CITY OF DODGEVILLE, IOWA COUNTY, WISCONSIN, AS FOLLOWS:

1. The City of Dodgeville shall perform snow removal operations along Iowa Street between Spring Street and Walnut Street after the accumulation of five (5) inches or more of snowfall; provided, however, that the Director of Public Works or the Street Department Foreman may authorize snow removal operations at any time deemed necessary to protect public health, safety, and welfare.
2. Snow removal operations conducted by the City under this policy shall occur on the Thursday following a qualifying snow event, unless otherwise directed by the Director of Public Works or the Street Department Foreman due to operational or safety considerations.
3. Pursuant to Section 8.07 of the municipal code of the City of Dodgeville, owners and occupants of properties abutting Iowa Street between Spring Street and Walnut Street shall be responsible for clearing snow and ice from all adjacent sidewalks and pedestrian areas within 24 hours and shall deposit such snow at the curb line in a manner that does not obstruct vehicular traffic or create hazardous conditions.
4. Nothing herein shall be construed to alter the limitation under Wis. Stat. sec. 893.83 on actions against the City for damages for injuries sustained by reason of an accumulation of snow or ice that has existed for less than 3 weeks.

Adopted and approved this \_\_\_\_ day of \_\_\_\_\_, 2026.

\_\_\_\_\_  
Barry Hottmann, Mayor

ATTEST:

\_\_\_\_\_  
Emily Wolfe, Interim City Clerk

DRAFT

# UTILITY BILL ADJUSTMENT

**CUSTOMER** Chris Keenan  
**LOCATION** 109 W Madison St  
**REASON** Pipe leaking. Water did not go down drain to sewer plant

DATE	CONSUMPTION PRIOR TO LEAK (GAL)	AVG CONSUMPTION PRIOR TO LEAK (GAL)
11/17/2025	747	2051
12/15/2025	3761	
1/15/2026	1646	

DATE	CONSUMPTION WITH LEAK (GAL)	AVG CONSUMPTION PRIOR TO LEAK (GAL)	EXTRA USEAGE (GAL)	SEWER CHARGE /1000 GAL	REFUND
2/16/2026	6991	2051	4940	\$6.75	\$33.34
3/17/2026	18318	2051	16267	\$6.75	\$109.80
4/15/2026	37679	2051	35628	\$6.75	\$240.49
<b>TOTAL REFUND</b>					<b>\$383.63</b>

**Garbage Can Quotes**

Product	Note	Quantity	Cost per Unit	Shipping	Total
Barco, Recycled Plastic Round Receptacles with Dome Lid	50 year guarantee	12	\$ 475.00	746.32	\$ 6,446.32
Victor Stantly, FC-12 (Same design as existing)	Quote from 7/25	12	\$ 1,280.00	Unk	\$ 15,360.00
Barco, Commercial Steel Waste Receptacles		12	\$ 729.00	490.32	\$ 9,238.32
Barco Two-Tone Panel Design Waste Receptacle	50 year guarantee	12	\$ 529.00		\$ 6,348.00
Barco, Acclaim Double Side-Load Receptacle	50 year guarantee	12	\$ 1,319.00		\$ 15,828.00
Barco, Concrete Receptacle	2 year guarantee	12	\$ 609.00		\$ 7,308.00
Uline, Dog Waste System, 10 gal	Sign, dispenser included	4	\$ 448.00		\$ 1,792.00
Uline, Recycling Trash Cans		12	\$ 585.00		\$ 7,020.00
Uline, Ranger Trash Cans	Mt Horeb has these DT	12	\$ 505.00		\$ 6,060.00
Sodaworks, Refurbish existing, Highland	Sandblast and repaint - 7/25	12	\$ 939.17		\$ 11,270.00

Barco, Recycled Plastic Round Receptacles with Dome Lid



Barco, Commercial Steel Waste Receptacles



Victor Stanly, FC-12



Sodaworks, Refurbish existing



Barco, Two-Panel Design Waste Receptacle



Barco, Acclaim Double Side-Load Receptacle



Uline, Ranger Trash Cans



Uline, Recycling Trash Cans



Uline, Dog Waste System, 10 gal



Barco, Concrete Receptacles

